

General

The AV201A is a member of the Serialboxx® family of cards. The AV201A is a one by eight video distribution amplifier with a differential input. Common mode rejection ratio is greater than 60dB at 60Hz. A trim control allows level adjustments of +or - 3 dB. An adjustable equalizer is included allowing for equalization of cable runs up to 100m. In installations where differential inputs or runs are involved and clamping inputs are required we recommend the use of the AV202A DA. Input and output connections to the AV201A are made on BNC connectors located on the rear of the MF100 frame. All inputs of the AV201A are 75 Ohms.

Product Specifications

Input Impedance	75 Ohm
Input Level	1V p-p, nominal
Input Return Loss	46dB @ 3.58MHz
Output Impedance	75 Ohm
Output Level	1V p-p, terminated
Frequency Response	better than 0.05dB @ 3.58MHz
Differential Gain	better than 0.15% @ 3.58MHz
Differential Phase	better than 0.15 degree @ 3.58MHz
Signal to Noise	better than 60dB 5MHz BW

General

Power Requirements	+/- 22 VDC, 80 mA
Dimensions	270mm x70mm x25.4mm (10.60"x2.75"x1.0")
Weight	310g (.682 lbs)

Functional

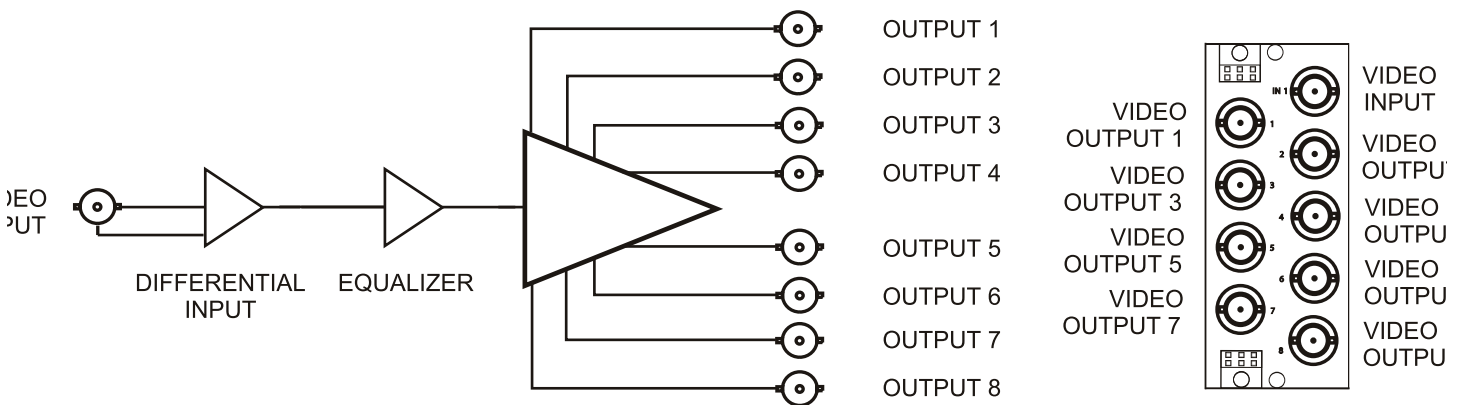

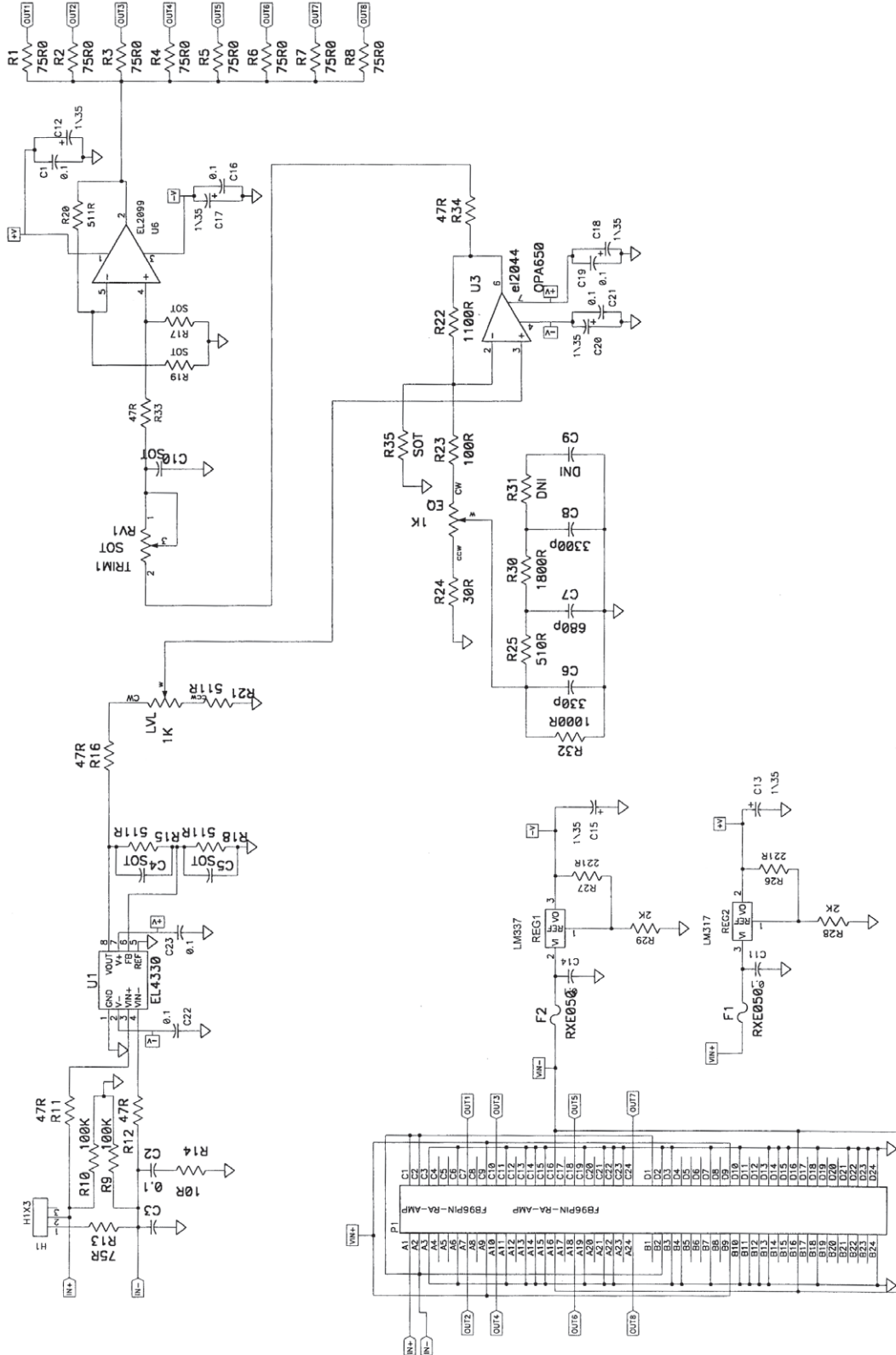

Warranty

All Ward-Beck Systems Ltd. Products are warranted against defective materials and workmanship for a period of one year from the date of shipment

Ward-Beck Systems Ltd. Will repair or replace, as its opinion and without charge, all said products or parts thereof which upon factory inspection prove to be defective during the warranty period. Provided that:

1. The original serial numbers are intact and have not been tampered with
2. The purchaser shall return any equipment or parts thereof to Ward-Beck Systems Ltd. Only after obtaining prior authorization and shipping instructions from the factory. (Ward-Beck Systems Ltd. Reserves the right to inspect or repair the equipment on the purchaser's premises)
3. The purchaser assumes the obligations for all expenses in connection with the shipping and return of such goods, once authorization has been obtained

This warranty does not cover items normally considered expendable, such as fuses and lamps.

This warrant does not cover damages caused by misuse, accident, neglect, unauthorized alteration, repair by unauthorized personnel, or damages caused by act of God, war, or civil insurrection.

In no event shall Ward-Beck Systems Ltd. Be liable for consequential damages. Ward-Beck Systems Ltd shall have the rights to final determination as to the application of this warranty.

Ward-Beck Systems Ltd. Reserves the right, at any time and without notice, to make changes in its equipment, components, specifications or design, as may be warranted by progress in state-of-the-art technology.

Ward-Beck Systems Ltd. Reserves the right to make design changes, additions to, and improvements in its products, without obligation to install such revisions in products previously manufactured.

The warranty set forth herein is in lieu of all other warranties expressed or implied, including the warranties of merchantability and fitness.

Contact

Ward-Beck Systems Ltd.

455 Milner Avenue, Unit 10
Toronto, Ontario, Canada
M1B 2K4

Toll Free (North America) - 800.771.2556

International - 416.335.5999

Fax - 416.335.5202

Sales Inquiries - sales@ward-beck.com

Product Support - support@ward-beck.com