

General

The Audio Bit Buddy™ is a low cost, portable belt pack unit for monitoring digital audio (AES/EBU, S/PDIF) or analog audio signals. The Audio Bit Buddy™ has a headphone output, and LEDs to display basic signal parameters and the “health” of a digital audio signal.

The Audio Bit Buddy™ is well suited for use in professional and consumer environments, such as broadcast installations, production studios, signal distribution facilities, or any other place where digital or analog audio signals are used. Analog or digital program audio can be listened to on the stereo headset output and left and right levels are displayed on the LED bar graph meters.

When monitoring AES/EBU or S/PDIF signals, the Audio Bit Buddy™ displays many critical signal parameters such as sampling frequency, audio level, emphasis, professional or consumer format and any data error that may be occurring. If data errors are detected, detailed information can be displayed for system analysis and troubleshooting. The digital input will accept signals with sampling frequencies from 30kHz to 50kHz..

Product Specifications

Input Impedance	110 Ohm (75 Ohm requires IMP-1M)
Input Level	0.2-7 Vp-p
Sampling Frequency Range	30kHz to 50kHz
D-to-A Converter	18 bit
Frequency Response	+/-0.5dB 20Hz to 20kHz

General

Power Requirements	AC Mains = 90-230V AC/50 or 60Hz Battery Pack = 12V NICAD
Dimensions	4.5”w x 8”h x 3.75”d/114mm x 203mm x 95mm
Weight	1.6kg (3.5 lbs)

Setup and Installation

Operational Features

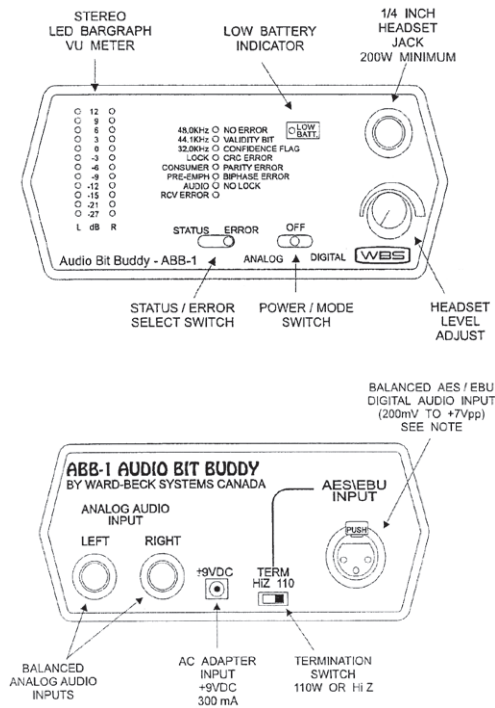

NOTE: To monitor digital signals in a 75Ω environment, we recommend the use of a WBS IMP-1M 75Ω to 110Ω impedance converter.

Displays

Stereo Meter

The Audio Bit Buddy™ is equipped with a stereo bar graph audio meter. Two Columns of twelve LEDs cover the range from -21 to +18 dBu. The unit is factory calibrated to read 0 VU for digital signals of -20 dBFS or analog signals of +4dBu. (Calibration for other standards can be implemented. Please consult the factory).

The following STATUS indicators may be illuminated if the digital audio bit stream is in good condition:

- AUDIO** - Data detected is true AES/EBU audio data.
- PRE-EMPHASIS** - Encoded channel emphasis is enabled.
- CONSUMER** - The channel status data block is set for consumer use
- LOCK** - Locked to a signal with a sampling frequency other than 32kHz, 44.1kHz or 48kHz.
- 32 kHz** - Locked to a signal with a sampling rate of 32kHz.
- 44.1 kHz** - Locked to a signal with a sampling rate of 44.1kHz.
- 44.8 kHz** - Locked to a signal with a sampling rate of 44.8kHz.

NOTE: Only one of the four sampling rate indicators can be illuminated.

If the STATUS/ERROR switch is in the ERROR position and no error is detected, the NO ERROR LED will be illuminated. It is recommended that the switch be left in the STATUS mode unless the RCV ERROR LED is illuminated.

The RCV ERROR indicator will illuminate if the digital audio signal is absent or the data is corrupted. Receive errors are prioritized and only the higher error will be indicated,

- NO LOCK** - Signal absent or data is corrupted beyond its recoverable limits (Highest priority).
- BIPHASE ERROR** - Biphasic coding of the signal is incorrect.
- PARITY ERROR** - Parity bit of the incoming data is not set as specified.
- CRC ERROR** - CRC (Cyclic Redundancy Check) value calculated for the receiver signal does not mate the CRC byte of the channel status word.
- CONFIDENCE FLAG** - Indicates an eye pattern violation, it is a warning that the incoming signal is approaching the limits beyond which a reliable recovery may be jeopardized. This is typically caused by the band limiting effects of long cable runs.
- VALIDITY BIT** - Validity bit of AES/EBU bit stream is high, indicating that the signal is not strong for D to A conversion.

NOTE: In the analog mode, the RCV ERROR/NO LOCK LED is illuminated to indicate power on.

POWER

The Audio Bit Buddy™ is powered by four AA Ni-Cad rechargeable or from a 9V, 300 mA AC adapter. The adapter can recharge the batteries and power the unit simultaneously. To replace the batteries, remove the two screws on either side of the housing and carefully slide the assembly from the housing. **NOTE:** Use Ni-Cad AA cells only!

Specifications

Specifications	Digital	Analog
Input Standard	AES/EBU transformer balanced on 3 pin XLR connectors (unbalanced via optional XLR/BNC adaptor)	2 inputs (L&R) balanced on 1/4" stereo phone jacks.
Input Impedance	Selectable HiZ or 110Ω (75Ω via IMP-1M adaptor)	Greater than 20 KΩ
Input Level	200m Vpp to max 7Vpp	18dBu (before clip)
D/A Converter	18 bit resolution	
Sample Frequency Range	30kHz to 50 kHz	
Frequency Response	20Hz to 20kHz ±1/2dB	20Hz to 20kHz ±1/2dB
Headphone Output	1/4" stereo phone jack	(600 Ω headphones)

Setup and Installation

Connecting To The Bit Buddy

The ABB-1 uses 3-pin XLR for an input connector and is wired as shown below. The input impedance can be switched between 110Ω and HiZ(>20k). If unbalanced 75Ω monitoring is required, Ward Beck offers a full line of impedance matching products. As shown below, the IMP-1M is a single in line impedance converter which will match 75Ω lines to the 110Ω input of the ABB-1.

Balanced Digital Audio Input

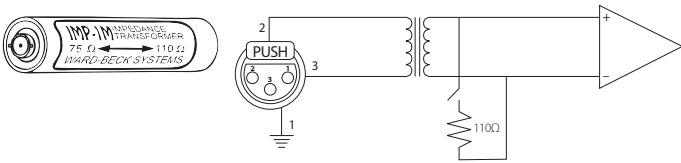

Balanced Analog Audio Output

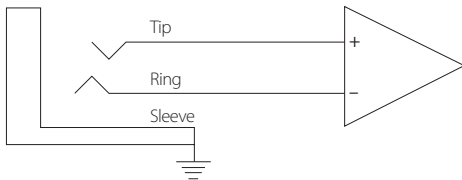

Headset Output

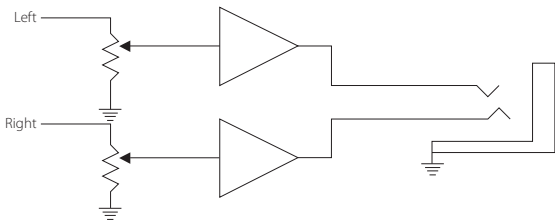

Digital Audio Overview

In order to interpret the information displayed when using the ABB-1 to monitor digital audio signals, it may be beneficial to have some understanding of the AES/EBU digital audio standards and the transmission of techniques employed.

The Data Bit Stream

The recommended interface for serial transmission of linearly represented stereo audio data is defined by the AES/EBU (Audio Engineering Society/European Broadcast Union) standard, AES-1985 and later amendments.

The standard allows for audio data transmission of 16 to 24 bits sampled at a rate of 30 to 50 kHz. This data is organized as sub frames, frames and channel status blocks. As illustrated in Fig 1, a sub frame consists of a preamble, 24 audio data bits, validity bit (V), user data bit (U), channel status bit (C) and sub frame parity bit (P). Each stereo sample or frame comprises two sub frames, A and B. Sub frames A and B represent the left and right program information of the stereo sample respectively.

The validity bit indicates whether the audio sample rate is suitable for conversion to analog. The Audio Bit Buddy™ validity error warns you when this bit is set. The Audio Bit Buddy™ also tests the sub frame parity bit and will warn you if an error is detected.

A Block structure is used to convey information in the (C) and (U) bits. A block consists of 192 frames, as shown in Fig. 2. The 192 channel status (C) and the user status bit (U) are assembled at the end of the block to form 24 bytes for user and channel status information. The channel status block carries information associated with the audio channel. Examples of this information in the block are pre-emphasis, sampling rate, length of audio sample etc. The 24th byte of the channel status block carries the CRC (Cyclic Redundancy Check) value that is used to test the validity of the entire channel status block upon reception. The ABB-1 will calculate the CRC of the first 23 bytes of the channel and status block and compare it to the received value in byte 24. If the CRC does not match the ABB-1 will indicate a CRC error.

Fig. 1

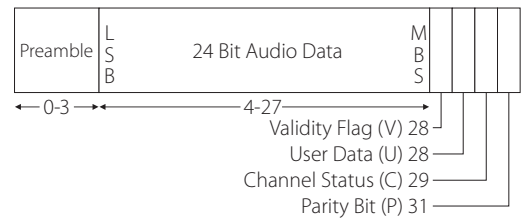
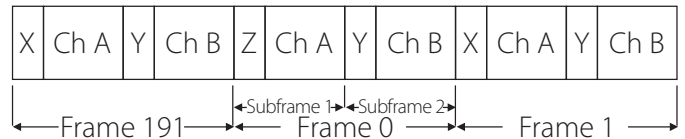

Fig. 2



Transmission

The serial data is coded in a biphas mark format (See Fig. 3). This format effectively changes the digital data from logic levels into transitions. A logic 1 level will cause a transition within the bit period while the level 0 will not. Transitions will separate each bit period. This biphas format has the advantage of being dc free, polarity insensitive and eases clock recovery. It should be noted that the preamble sync bits are unique in that they violate this coding format, i.e. they do not have transitions on all the bit boundaries. If this coding structure is violated, the ABB-1 will indicate a biphas error.

Fig. 3

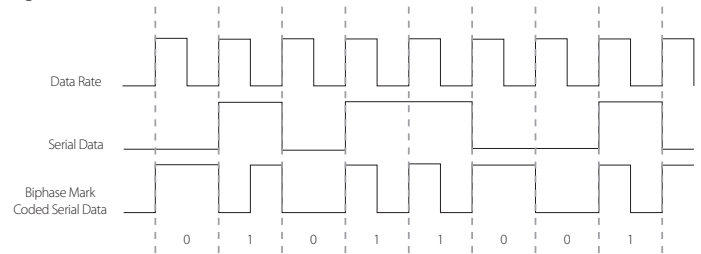

Setup and Installation

From the description of the digital audio signal data it can be determined that every stereo sampler requires 64 bits of data and at a sample rate of 48kHz this translates to a bit rate of 3.072 MHz. With the biphase coding, logic ones are at twice this rate.

For balanced AES/EBU transmissions 110Ω shielded, twisted pair cable is recommended and for unbalanced transmissions, 75Ω co-axial cable. As digital signals are inherently rich in harmonics, they require a wide bandwidth for distortion free transmission. The low pass filter effects of the cable will cause the signal to distort as cable lengths increase, see Fig. 4. As shown in the eye diagram in Fig. 5, the AES/EBU standard dictates that a receiver shall correctly sense data with a minimum voltage of 200mV and a width equal to 25% of the biphase symbol rate. An eye pattern can be seen on an oscilloscope by triggering it so that the pulses overlap. When a signal approaches these limits, the ABB-1 will indicate a confidence error as a warning that it may not be able to receive the signal correctly.

Fig.4

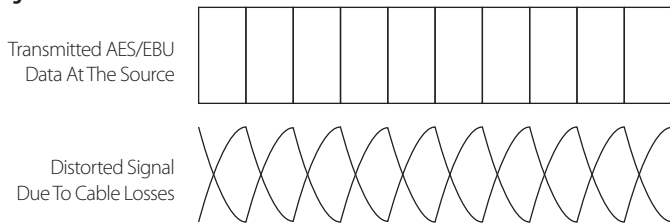
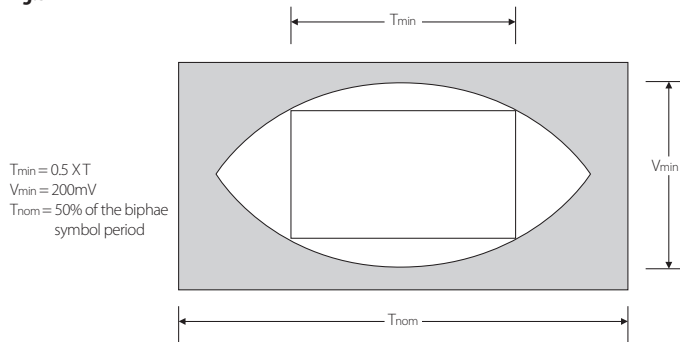
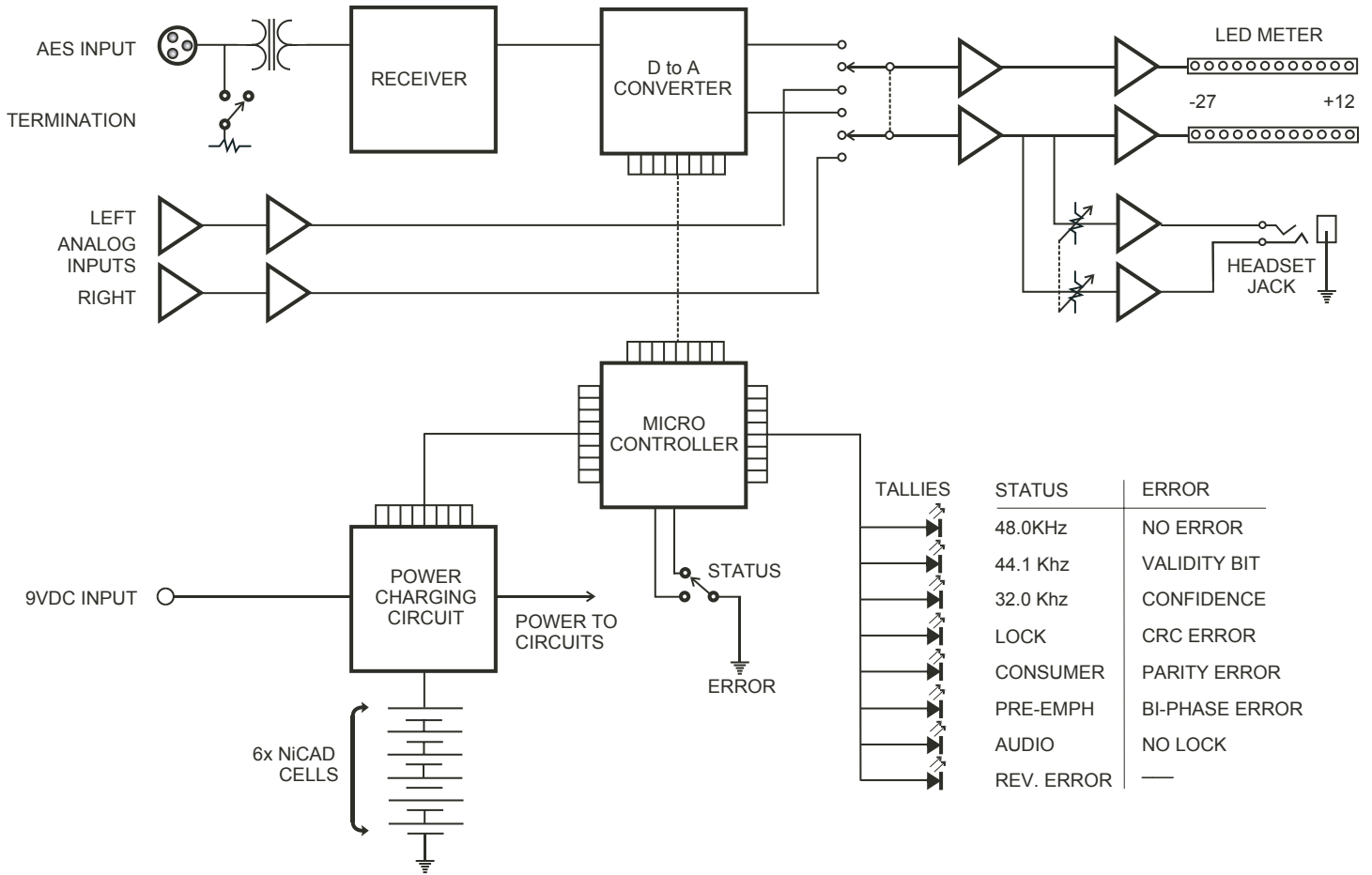

Fig.5





STATUS	ERROR
48.0Khz	NO ERROR
44.1 Khz	VALIDITY BIT
32.0 Khz	CONFIDENCE
LOCK	CRC ERROR
CONSUMER	PARITY ERROR
PRE-EMPH	BI-PHASE ERROR
AUDIO	NO LOCK
REV. ERROR	—

Warranty

All Ward-Beck Systems Ltd. Products are warranted against defective materials and workmanship for a period of one year from the date of shipment

Ward-Beck Systems Ltd. Will repair or replace, as its opinion and without charge, all said products or parts thereof which upon factory inspection prove to be defective during the warranty period. Provided that:

1. The original serial numbers are intact and have not been tampered with
2. The purchaser shall return any equipment or parts thereof to Ward-Beck Systems Ltd. Only after obtaining prior authorization and shipping instructions from the factory. (Ward-Beck Systems Ltd. Reserves the right to inspect or repair the equipment on the purchaser's premises)
3. The purchaser assumes the obligations for all expenses in connection with the shipping and return of such goods, once authorization has been obtained

This warranty does not cover items normally considered expendable, such as fuses and lamps.

This warrant does not cover damages caused by misuse, accident, neglect, unauthorized alteration, repair by unauthorized personnel, or damages caused by act of God, war, or civil insurrection.

In no event shall Ward-Beck Systems Ltd. Be liable for consequential damages. Ward-Beck Systems Ltd shall have the rights to final determination as to the application of this warranty.

Ward-Beck Systems Ltd. Reserves the right, at any time and without notice, to make changes in its equipment, components, specifications or design, as may be warranted by progress in state-of-the-art technology.

Ward-Beck Systems Ltd. Reserves the right to make design changes, additions to, and improvements in its products, without obligation to install such revisions in products previously manufactured.

The warranty set forth herein is in lieu of all other warranties expressed or implied, including the warranties of merchantability and fitness.

Contact

Ward-Beck Systems Ltd.

455 Milner Avenue, Unit 10
Toronto, Ontario, Canada
M1B 2K4

Toll Free (North America) - 800.771.2556

International - 416.335.5999

Fax - 416.335.5202

Sales Inquiries - sales@ward-beck.com

Product Support - support@ward-beck.com